

**MAX POWER BATTERY**

**C R14**

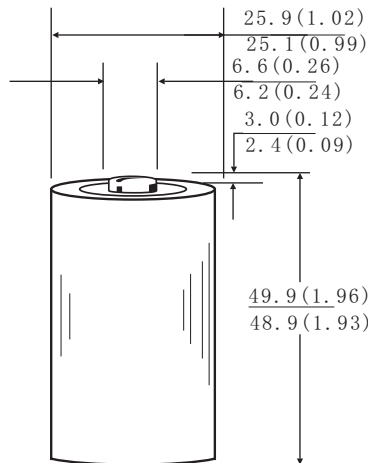

**Dimensions**



Unit: mm (inch)

**Chemical System :** Zinc-Manganese Dioxide  
(Zinc Chloride Electrolyte)

**Camelion Model :** R14P

**IEC No. :** R14P

**ANSI/NEDA No. :** 14D ( C )

**Average Weight :** 42g

**Dimension ( Ø x H ) :** 25.5<sup>±0.4</sup> x 49.4<sup>±0.5</sup> mm  
1.0<sup>±0.02</sup> x 1.94<sup>±0.02</sup> inch

**Terminals :** Flat

**Nominal Voltage :** 1.5Volts

**Average Capacity :** 3600 mAh to 0.8 volts

(20±2°C , Rated capacity at 25 mA continuous drain )

**Jacket :** Aluminum Foil Label

