

## MAX POWER BATTERY

## 9V 6F22

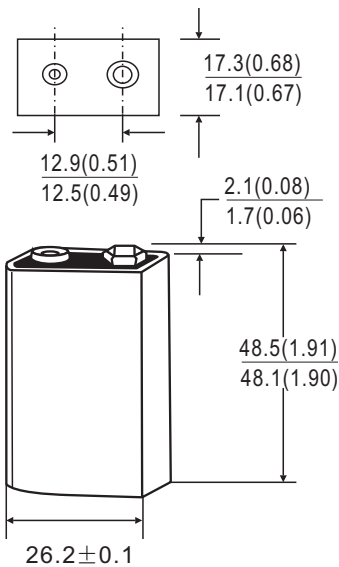

Unit: mm(inch)

**Chemical System :** Zinc -Manganese Dioxide  
( Zinc Chloride Electrolyte )

**Camelion No. :** 6F22

**IEC No. :** 6F22

**ANSI/NEDA No. :** 1604D(9V)

**Average Weight :** 36.4g

**Dimension(LxWxH) :** 26.2<sup>±0.1</sup> x17.2<sup>±0.1</sup> x48.3<sup>±0.2</sup> mm  
1.03<sup>±0.004</sup> x0.69<sup>±0.004</sup> x1.90<sup>±0.008</sup> inch

**Terminals :** Minature Snap

**Nominal Voltage :** 9.0Volts

**Average Capacity :** 300mAh to 4.8 volts  
( 20±2°C , Rated capacity at 5 mA continuous drain )

**Jacket :** Metal

